



**MORRIS**

**W70137EED**

**W70195EED**



**CHEST FREEZER**

**INSTRUCTION MANUAL**

Please read this manual carefully before use this product

# SAFETY



## WARNING!

It is hazardous for anyone other than authorized service personnel to carry out servicing or repairs which involves the removal of covers. To avoid the risk of an electric shock do not attempt to repair this appliance yourself.

## WARNING!

Risk of fire / flammable materials.



## Safety tips

Do not use electrical appliances such as a hair dryer or heater to defrost your Freezer.

Containers with flammable gases or liquids can leak at low temperatures.

Do not store any containers with flammable materials, such as spray cans, fire extinguisher refill cartridges etc. in the Freezer.

Do not place carbonated or fizzy drinks in the Freezer compartment. Ice lollies can cause "Frost/Freeze burns". If consumed straight from the Freezer.

Do not remove items from the Freezer compartment if your hands are damp/wet, as this could cause skin abrasions or "Frost/Freezer burns". Bottles and cans must not be placed in the Freezer compartment as they can burst when the contents freeze.

Manufacturer's recommended storage times should be adhered to. Refer to relevant instructions.

Do not allow children to tamper with the controls or play with the Freezer. The Freezer is heavy. Care should be taken when moving it. It is dangerous to alter the specification or attempt to modify this product in any way.

Do not store inflammable gases or liquids inside your Freezer.

If the power cable is damaged, it must be replaced by the manufacturer, its service agent, or similarly qualified persons in order to avoid a hazard.

This appliance can be used by children aged from 8 years and above and persons with reduced physical, sensory or mental capabilities or lack of experience and knowledge if they have been given supervision or instruction concerning use of the appliance in a safe way and understand the hazards involved. Children shall not play with the appliance. Cleaning and user maintenance shall not be made by children without supervision.

This refrigerating appliance is not intended to be used as a built-in appliance.

This appliance is intended to be used in household and similar applications such as

- staff kitchen areas in shops, offices and other working environments;
- farm houses and by clients in hotels, motels and other residential type environments;
- bed and breakfast type environments;
- catering and similar non-retail applications.

Keep ventilation openings, in the appliance enclosure or in the built-in structure, clear of obstruction.

Do not use mechanical devices or other means to accelerate the defrosting process, other than those recommended by the manufacturer.

Do not damage the refrigerant circuit.

Do not use electrical appliances inside the food storage compartments of the appliance, unless they are of type recommended by the manufacturer.

**D**o not store explosive substances such as aerosol cans with a flammable propellant in this appliance.

**T**his appliance is not intended for use by persons (including children) with reduced physical, sensory, or mental capabilities, or lack of experience and knowledge, unless they have been given supervision or instruction concerning use of the appliance by a person responsible for their safety. Children should be supervised to ensure that they do not play with the appliance.

- **WARNING:** Keep ventilation openings, in the appliance enclosure or in the built-in structure, clear of obstruction.
- **WARNING:** Do not use mechanical devices or other means to accelerate the defrosting process, other than those recommended by the manufacturer.
- **WARNING:** Do not damage the refrigerant circuit.
- **WARNING:** Do not use electrical appliances inside the food storage compartments of the appliance, unless they are of the type recommended by the manufacturer.
- **WARNING:** Refrigerating appliances – in particular, a refrigerator-freezer Type I – might not operate consistently (possibility of defrosting of contents or temperature becoming too warm in the frozen food compartment) when sited for an extended period of time below the cold end of the range of temperatures for which the refrigerating appliance is designed;
- **WARNING:** The necessity that, for doors or lids fitted with locks and keys, the keys be kept out of the reach of children and not in the vicinity of the refrigerating appliance, in order to prevent children from being locked inside.
- **WARNING:** The refrigerant used in your appliance and insulation materials requires special disposal procedures.
- **WARNING:** When positioning the appliance, ensure the supply cord is not trapped or damaged.
- **WARNING:** Do not locate multiple portable socket-outlets or portable power supplies at the rear of the appliance  
Children aged from 3 to 8 years are allowed to load and unload refrigerating appliances. To avoid contamination of food, please respect the following instructions:
  - Opening the door for long periods can cause a significant increase of the temperature in the compartments of the appliance.
  - Clean regularly surfaces that can come in contact with food and accessible drainage systems.
  - Clean water tanks if they have not been used for 48 h; flush the water system connected to a water supply if water has not been drawn for 5 days.
  - Store raw meat and fish in suitable containers in the refrigerator, so that it is not in contact with or drip onto other food.
  - Two-star frozen-food compartments are suitable for storing pre-frozen food, storing or making ice-cream and making ice cubes.
  - One-, two- and three-star compartments are not suitable for the freezing of fresh food.
- If the refrigerating appliance is left empty for long periods, switch off, defrost, clean, dry, and leave the door open to prevent mould developing within the appliance.

### Climate Range

The information about the climate range of the appliance is provided on the rating plate. It indicates at which ambient temperature (that is, room temperature, in which the appliance is working) the operation of the appliance is optimal (proper).

Climate range	Permissible ambient temperature
SN	from +10°C to +32°C
N	from +16°C to +32°C
ST	from +16°C to +38°C
T	from +16°C to +43°C

Note: Given the limit values of the ambient temperature range for the climate classes for which the refrigerating appliance is designed and the fact that the internal temperatures could be affected by such factors as location of the refrigerating appliance, ambient temperature and the frequency of door opening, the setting of any temperature control device might have to be varied to allow for these factors, if appropriate.

If the power cable is damaged, it must be replaced by the manufacturer, its service agent, or similarly qualified persons in order to avoid a hazard.



Note: When operating in an environment other than the specified climate type (i.e., beyond the rated ambient temperature range), the appliance may not be able to maintain the desirable compartment temperatures.

### Grounding requirement

Your refrigerator must be grounded. Your refrigerator is equipped with a cord having a grounding wire with a grounding plug. The plug must be inserted into an outlet that is correctly installed and grounded.

Incorrect use of the grounding plug can result in a risk of electric shock. Consult a qualified electrician or service person if the grounding instructions are not completely understood, or if doubt exists as to whether your refrigerator is correctly grounded.

## Locks

If your Refrigerator is fitted with a lock, keep the key out of reach and not in the vicinity of the appliance to prevent children being entrapped. When disposing of an old Refrigerator, break off any old locks or latches as a safeguard.

## Freon-free

The freon-free refrigerant (R600a) and the foaming insulation material (cyclopentane) that is environmentally friendly are used for the refrigerator, causing no damage to the ozone layer and having a very small impact on the global warming. R600a is flammable, and sealed in a refrigeration system, without leakage during normal use. But, in case of refrigerant leakage due to the refrigerant circuit being damaged, be sure to keep the appliance away from open flames and open the windows for ventilation as quickly as possible.

## NAMES OF THE PARTS

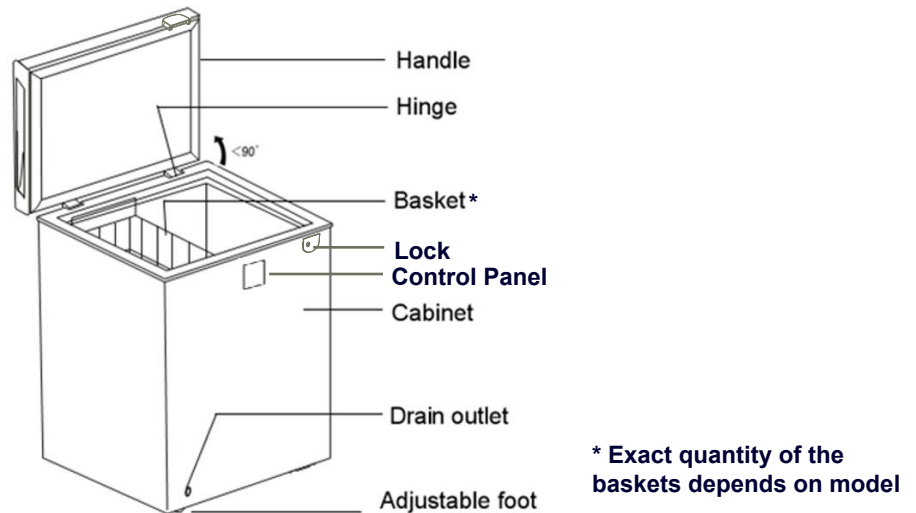

**⚠WARNING⚠:** Never touch the interior of the Freezer Chamber or frozen foods in the compartment with wet hands as this could result in frost bite.

## TRANSPORTATION INSTRUCTIONS

The appliance should be transported only in a vertical upright position. The packing as supplied must be intact during transportation.

If during transport, the product has been transported horizontally, it must only be laid on its left-hand side (when facing the door front) and it must not be operated for at least 4 hours to allow the system to settle after the appliance is brought back to upright position.

1. Failure to comply with the above instructions could result in damage to the appliance. The manufacturer will not be held responsible if these instructions are disregarded.
2. The appliance must be protected against rain, moisture, and other atmospheric influences.

**IMPORTANT:** Care must be taken while cleaning / carrying the appliance to avoid touching the condenser metal wires at the back of the appliance, as you might injure your fingers and hands or damage your product.

**IMPORTANT:** This appliance is not designed for stacking with any other appliance. Do not attempt to sit or stand on top of your appliance as it is not designed for such use. You could injure yourself or damage the appliance.

**IMPORTANT:** Make sure that mains cable is not caught under the appliance during and after carrying / moving the appliance, to avoid the mains cable becoming cut or damaged."

When positioning your appliance take care not to damage your flooring, pipes, wall coverings etc. Do not move the appliance by pulling by the lid or handle. Do not allow children to play with the appliance or tamper with the controls. Our company declines to accept any liability should the instructions not be followed.

## INSTALLATION INSTRUCTIONS

1. If possible, avoid placing the appliance near cookers, radiators or in direct sunlight as this will cause the compressor to run for long periods. If installed next to a source of heat or refrigerator, maintain the following minimum side clearances:  
From Cookers 4" (100 mm)  
From Radiators 12" (300 mm)  
From Fridges 4" (100 mm)
2. Make sure that sufficient room is provided around the appliance to ensure free air circulation. Ideally, A space of no less than 10cm must be left around the freezer, and ensure you allow gaps as shown in the below diagram.
3. The appliance should be located on a smooth surface.

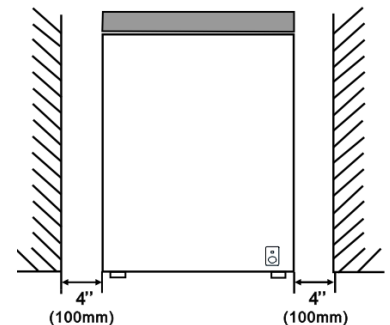

4. It is forbidden to use the refrigerator outdoors.
5. Protection from moisture. Do not locate the freezer in moist space to avoid the metal parts rusty. And do not spray water to the freezer, otherwise it will weaken the insulation and causes current leakage.
6. Refer to "Cleaning and Care" section to prepare your appliance for use.
7. If the freezer is installed in unheated areas, garages etc., in cold weather condensation may form on the outer surfaces. This is quite normal and is not a fault. Remove the condensation by wiping with a dry cloth.

### STARTING

Before you start to use the freezer,

1. Check that the interior is dry and air can circulate freely at the rear.
2. Clean the interior as recommended under "CLEANING AND CARE".
3. Insert the plug into the wall socket and switch on the electricity supply, then the green light is on.
4. You will hear a noise as the compressor starts up. The liquid and gases sealed within the refrigeration system may also give rise to noise, whether the compressor is running or not which is quite normal.
5. If you going to store already frozen food, open the freezer lid and check that the freezer has reached the correct temperature. Then you can put in your already frozen food.
6. Do not load the appliance immediately after it is switched on. Wait until the correct storage temperature has been reached. We recommend that you check the temperature with an accurate thermometer.

### Important Notes:

- In case of a power failure, do not open the lid. Frozen food will not be affected if the failure lasts for less than 20 hours. If the failure is longer, then the food should be checked and eaten immediately, or cooked and then refrozen.
- If the lid of the chest freezer is difficult to be opened just after being closed, don't worry. This is due to the pressure difference, which will equalize after a few minutes, allowing the lid to be opened normally.

### TEMPERATURE CONTROL



#### ■Initial power-up

When the appliance is powered on for the first time, all display lights will light up and then shows the actual inside temperature.

#### ■Locking and Unlocking

- If any button is not pressed for around 30 seconds, it will automatically enter the locked state and the temperature cannot be set.
- In the locked state, if you press any button for a short time (less than 3 seconds), the setting temperature would flash for about 5 seconds, and then the actual inside temperature will be displayed for about 5 seconds.
- In the locked state, press the "Mode/3 Seconds Unlock" button for around 3 seconds at least to unlock the mode and temperature setting.

#### ■Mode selection

- In the unlocked state, press the "Mode/3 seconds unlock" button, and the 5 modes "Fridge (5°C) - Freezer (-18°C) – Cool (7°C) – Super Freeze(-20°C) – Deep freeze (-32°C)" can be chosen in a cycle.
- The maximum working time of the compressor in deep freezer mode shall be 24 hours, and it will automatically switch to "Freezer" mode after 24 hours.

#### ■Temperature adjustment

- In unlocked state, press the button "+" or "-" to adjust the temperature by 1°C each press. The temperature range shall be +10°C~-32°C.
- In unlocked state, if pressing the "+" or "-" button for around 2 seconds, the temperature will change continuously.

■ **Power off memory:** When the appliance is working normally, if it is powered on again after an unexpected power outage, the appliance will continue the working mode before the power outage.



**Due to individual factors of the refrigerator, the actual temperature in the box may have a certain error from the set temperature, which is a normal phenomenon and does not affect the normal use of the product.**

### STORING FROZEN FOOD

Prepackaged commercially frozen food should be stored in accordance with the frozen food manufacturer's instructions for a freezer compartment.

To ensure high quality is achieved by the frozen food manufacturer and the food retailer, the following should be remembered:

1. Put packets in the freezer as quickly as possible after purchase.
2. Do not exceed "Use By", "Best Before" dates on the packaging.

### FREEZING FRESH FOOD

Place fresh food to be frozen near the side walls to ensure fast freezing and away from the frozen food, if possible.

Never exceed this maximum capacity. Do not freeze too large a quantity at any one time.

The quality of the food is best preserved when it is frozen right through to the center as quickly as possible.

Take special care not to mix frozen food and fresh food.

### DEFROSTING

Defrost twice a year or when a frost layer of around 7 mm (1/4") has been formed.

Alternatively, you may switch off the freezer at the socket outlet and pull out the mains plug.

Extract the water conduit and put in a water container.

All food should be wrapped in several layers of newspaper and stored in a cool place (e.g., fridge or larder).

Remove the freezer basket, and leave the lid open. Containers of warm water may be placed carefully in the freezer to speed up the defrosting.

Never use hairdryers, electrical heaters, or other such electrical appliances for defrosting. When defrosting is finished, flow out the defrost water which is collected at the bottom of the freezer as the below diagram and dry the interior thoroughly. Switch on the Fast Freeze and leave it on for about three hours.

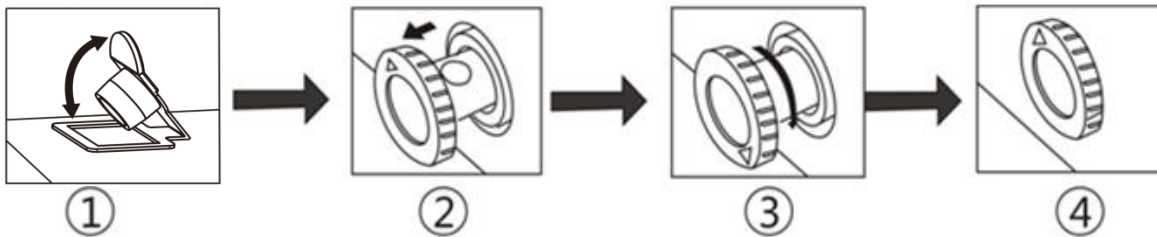

1. A drain outlet is designed at the bottom of the freezer liner, and when defrosting, remove its rubber cover, then defrosting water flows out and is discharged from the drain pipe.
2. Extract the water conduit by 20-25mm until the water hole can be seen.
3. Twist the water conduit until the arrow points downward.
4. After defrosting is done, make sure there is no more water coming out before put the water conduit in place and make the arrow point upward.

### How to use the ice-making box

Place the ice-making box in the upper position of the freezer compartment, so that it ices up as soon as possible.

#### Important Notes:

- Do not use pointed or sharp-edged objects such as knives or forks to remove the frost.
- Never use hairdryers, electrical heaters, or other such electrical appliances for defrosting.
- It is normal that water beads or frosts appear on the freezer collar and door gaskets in the wet weather, which will not affect the normal use. In such case, please clean it with a dry cloth in time!

#### CLEANING AND CARE

\*\* We recommend that you switch off the freezer at the socket outlet and pull out the mains plug before cleaning.

\*\* Never use any sharp abrasive instrument, soap, household cleaner, detergent, and wax polish for cleaning.

\*\* Use lukewarm water to clean the cabinet of the freezer and wipe it dry.

\*\* Use a damp cloth wrung out in a solution of one teaspoon of bicarbonate of soda to one pint of water to clean the interior and wipe it dry.

\*\* Excess deposit of ice should be removed on a regular basis using a plastic ice scraper available from your local store. Large accumulation of ice will impair the performance of the freezer.

\*\* If the freezer is not going to be used for a long period of time switch it off, remove all food, clean it and leave the lid ajar.

\*\* Check lid seals regularly to ensure they are clean and free from food particles.

#### Important Notes:

Never use water wash the compressor position, wipe it with a dry cloth thoroughly after cleaning to prevent rust.

#### DO'S AND DON'TS

- Do** – Defrost food from the freezer thoroughly in a fridge or in a microwave oven following defrosting and cooking instructions.
- Do** – Ensure that chest freezer lid is completely closed after each use.
- Do** – Defrost frozen meat completely before cooking.
- Do** – Close the lid gently.
- Do** – Check contents of the freezer at regular intervals.
- Do** – Clean and defrost your freezer regularly (See “Defrosting”)
- Do** – Keep food for as short a time as possible and adhere to “Best Before”, “Use By” dates.
- Do** – Store commercially frozen food in accordance with the instructions given on the packets that you buy.
- Do** – Always choose high quality fresh food and be sure it is thoroughly clean before you freeze it.
- Do** – Prepare fresh food for freezing in small portions to ensure rapid freezing.
- Do** – Wrap all foods in aluminum foil or freezer quality plastic bags and make sure any air is excluded.
- Do** – Wrap frozen food when you buy it and put it in to the freezer as soon as possible.
- Do** – Store small items in the basket provided.
- Do** – Remove ice cream from the freezer 10-20 minutes before serving.
- Don't** – Leave the lid open for long periods as this will make the freezer more costly to run and cause excessive ice formation.
- Don't** – Use pointed sharp edged objects such as knives, forks to remove the ice.
- Don't** – Put hot food in the freezer. Let it cool down first.
- Don't** – Put liquid-filled bottles or sealed cans containing carbonated liquids into the freezer as they may burst.
- Don't** – Store poisonous or dangerous substances in the freezer. Your freezer has been designed for the storage of edible foodstuffs only.
- Don't** – Consume ice-cream and water ices direct from the freezer. The low temperature may cause ‘freezer burns’ on lips.
- Don't** – Freeze fizzy drinks.
- Don't** – Try to keep frozen food which has thawed, it should be eaten within 24 hours or cooked and refrozen.
- Don't** – Remove items from the freezer with wet hands.
- Don't** – Shut the lid with force. You will damage the appliance.
- This appliance is not intended for use by persons (including children) with reduced physical, sensory or mental capabilities, or lack of experience and knowledge, unless they have been given supervision or instruction concerning use of the appliance by a person responsible for their safety.
- Children should be supervised to ensure that they do not play with the appliance.
- Do not store explosive substances such as aerosol cans with a flammable propellant in this appliance.
- This appliance is intended to be used in household and similar applications such as staff kitchen areas in shops, offices and other working environments; farm houses and by clients in hotels, motels and other residential type environments; bed and breakfast type environments catering and similar not-retail applications.
- If the supply cord is damaged, it must be replaced by manufacturer, its service agent or similarly qualified persons in order to avoid a hazard.

**Certifications**

Electrical information

This electrical appliance must be grounded.

This product is equipped with a plug, which is suitable for all houses equipped with sockets meeting the current specifications. If the fitted plug is not suitable for your socket outlets, it should be cut off and carefully disposed of. To avoid a possible shock hazard, do not insert the discarded plug into a socket.

This product complies the EEC directives.

<b>Correct Disposal of this product</b>	
	<p>This marking indicates that this product should not be disposed with other household wastes throughout the EU. To prevent possible harm to the environment or human health from uncontrolled waste disposal, recycle it responsibly to promote the sustainable reuse of material resources. To return your used device, please use the return and collection systems or contact the retailer where the product was purchased. They can take this product for environmentally safe recycling.</p>

**Warnings for disposal**

- ✘ Refrigerant and cyclopentane foaming material used for there frigerator are flammable. Therefore, when there frigerator is scrapped, it shall be kept away from any fire source and be recovered by a special recovering company with corresponding qualification other than be disposed by combustion, so as to prevent damage to the environment or any other harm.
- ✘ When there frigerator is scrapped, disassemble the doors, and remove gasket of door and shelves; put the doors and shelves in a proper place, so as to prevent trapping of any child.

**Changing the Light board**

- ✘ LED lamp can not replaced by user, if the LED lamp is damaged
- Please contact the nearest authority to replace it.

## Main technical parameters

Parameter \ Model	W70137EED	W70195EED
Climate	SN/N/ST/T	SN/N/ST/T
Total storage volume	137L	194L
Rated voltage	220-240V	220-240V
Rated Frequency	50Hz	50Hz
Rated current	0.6A	0.6A
Refrigerant & Weight	R600a 50g	R600a 65g
Weight	20kg	27kg
Physical vesicant	CYCLOPENTANE	CYCLOPENTANE

The ordered parts in the following table can be acquired from service provider channel  
 Amiridis - Savvidis SA  
 87A, 17th November str  
 55535, Pylea, Thessaloniki, Greece

Ordered part	Provided by	Minimum time required for provision
Thermostats	Professional maintenance personnel	At least 7 years after the last mode is launched on the market
Temperature sensors	Professional maintenance personnel	At least 7 years after the last mode is launched on the market
Printed circuit boards	Professional maintenance personnel	At least 7 years after the last mode is launched on the market
Light sources	Professional maintenance personnel	At least 7 years after the last mode is launched on the market
Door handles	Professional repaired and final users	At least 7 years after the last mode is launched on the market
DOOR HINGE	Professional repaired and final users	At least 7 years after the last mode is launched on the market
Trays	Professional repaired and final users	At least 7 years after the last mode is launched on the market
Baskets	Professional repaired and final users	At least 7 years after the last mode is launched on the market
Door gaskets	Professional repaired and final users	At least 7 years after the last mode is launched on the market

## **NOTICE ABOUT RECYCLING**



Your product is designed and manufactured with high quality materials and components which can be recycled and reused.

This symbol means that electrical and electronic equipment, at their end-of-life,

should be disposed of separately from your household waste. Please dispose of this equipment at your local community waste collection/ recycling centre.

In the European Union there are separate collection systems for used electrical and electronic products.

Please help us to conserve the environment we live in!

## **DECLARATION OF CONFORMITY**

Herewith, we state that this product complies with the requirements of below directives:

EMC-Directive: 14 / 30 / EU

Low Voltage Directive: 14/ 35 / EU

ErP Directive 09 / 125 / EC

CE Marking: 93 / 68 / EEC

RoHS Directive: 11 / 65 / EU & Delegated Directive (EU) 15 / 863

The detailed declaration of conformity can be found at

[www.morris.gr](http://www.morris.gr)





**Kalliopi Karyda & Co, LP**  
87A, 17is Noemvriou str.  
55535, Pylea, Greece  
Tel. 2316 006600  
Fax. 2316 006650  
[www.morris.gr](http://www.morris.gr)